

Power-Tarom

Solar Charge Controller

For telecommunications and hybrid systems

LC-Display for state of charge, voltage, currents, Ah
System parameters and functions are field adjustable
System data transmission on the DC powerline
IP65 Protection degree



Automatic compensation of voltage loss on the battery cable
140A charge and 70A load current
System voltage 12/24 or 48 Volt
High efficient hybrid regulator



Applications

The Power Tarom regulator series is designed for photovoltaic stand alone systems up to 5 to 7 kWp. By changing the SOC control mode into a voltage based mode, this Tarom regulator series can be connected in parallel to the battery for solar array up to 20kWp or more PV module power.

Field adjustable Parameters

- state-of-charge determination (SOC)
- optional: voltage controlled
- manual load disconnect
- self test
- battery capacity
- lead acid or gel/AGM battery
- acid density (specific gravity)
- boost charging level and time period
- equalisation charging level and time period
- high voltage disconnect (SOC or voltage)
- low voltage disconnect (SOC or voltage)
- load reconnection (SOC or voltage)
- load connection only during night after sunset
- by settable delay and time period
- temperature compensation value
- reset of factory preadjusted parameters

Features and Safety

- PWM battery charging at 20Hz
- built in data logger for up to 7 weeks
- storage capacity
- built in Ah counter
- one general alarm output (potential free)
- reverse polarity protection (all terminals)
- over current protection (battery)
- lightning protection
- IP65 protection class for outdoor installation

Technical data

	Power Tarom 2070	Power Tarom 2140	Power Tarom 4055	Power Tarom 4110
Nominal system voltage	12/24V	12/24V	48 V	48 V
Max. module current	70 (58A)	140 (116A)	55 (46A)	110 (92A)
Max. load current	70 (58A)	70 (58A)	55 (46A)	55 (46A)
All current values are for the same load and module current (=100%) at 20°C and 50°C (see graph below)				
Operating temperature range	-10°...+50° C			
Cable terminals	50 / 70 mm ²			
Weight & dimension	9 / 10 kg, 330x360x190 mm			
Enclosure	powder coated steel, aluminium heatsink			
Protection degree	IP 65			
Self consumption	12mA			
Overtemperature	75°C, reset at 65°C			
Oversvoltage	> 65V			
Field adjustable parameters	range	default		
End of charge voltage (HVD)	13.0..14,5V	13.7V		
Boost charge level	13.5..15.0V / 0.5..5h	14.7V / 2h		
Equalization charge level	14.0..15.5V / 0.5..5h	15.0V / 2h		
Load disconnect (SOC)	20..70% SOC	<30% SOC		
Low voltage disconnect (LVD)	11.0 ... 12.5V	11.4V		
Load reconnect (SOC)	40..90% SOC	>50% SOC		
Load reconnect (voltage)	11.8 ... 13,3V	12.6V		
Temperature compensation	-2mV...-8mV	-4mV / K		

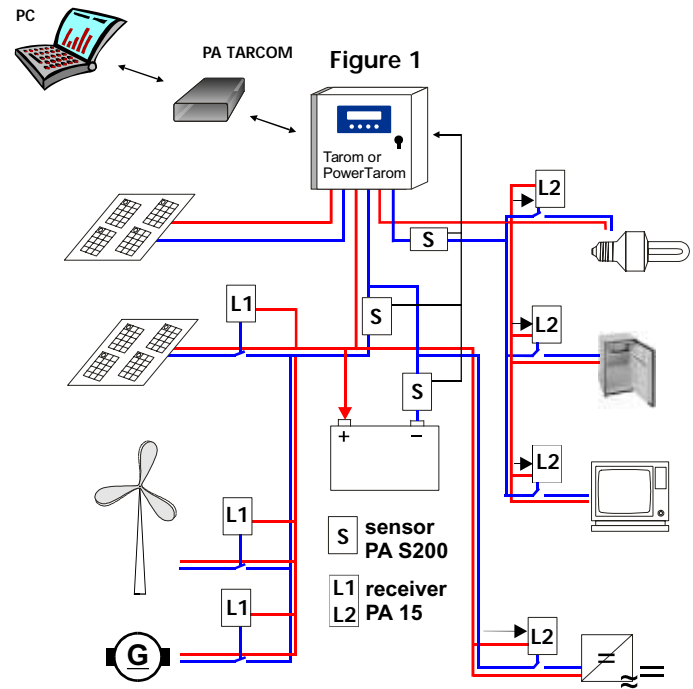
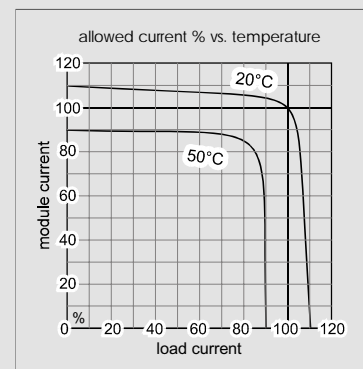

Options

- PA 15 remote control for back up generators such as wind or diesel generator (figure 1 "L1")
- PA 15 remote control for load control (priority switching), (figure 1 "L2")
- PA TARCOM external datalogger with 1MB storage capacity, RS232 interface, additional dry free contact and software
- PA HS200 external hall shunt for current and SOC measurement (figure 1 "S" on battery)

Two Line LC-Display

```
SOC  Bat  Charge  Load
98% 13.7  26   17
SOC = 98%
```

```
98% 13.7  00   00
U Bat = 13.70V
```

```
37% 11.5  00   04
missing module
```

```
98% 13.7  22   04
I mod = 21.5A
```